

EHN, EHV

max 90mm

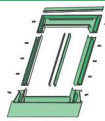

max 45mm

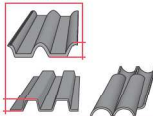
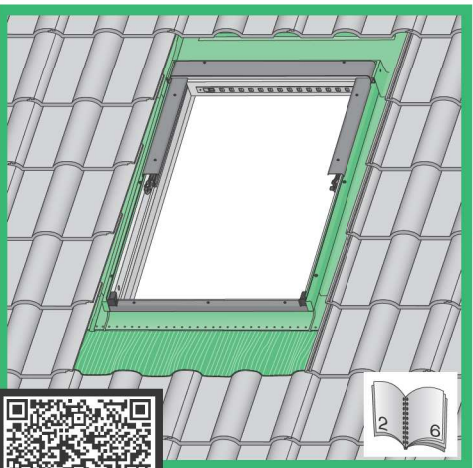
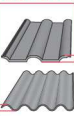

EZN, EZV, EZJ

<http://www.fakro.com/download/film-installation-instructions/flashing/>

max 90mm

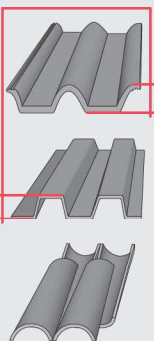

EHN

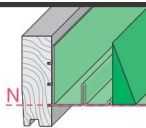

EHV

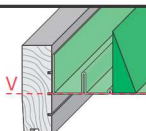

-

-

-

max 45mm

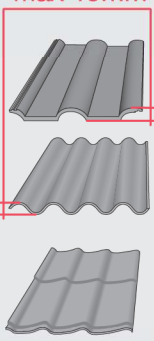

EZN

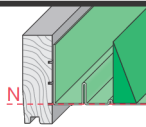

EZV

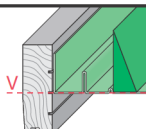

EZJ

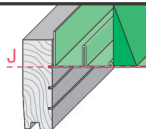

max 45mm



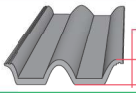

max 90mm

EHN
EHV

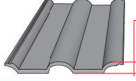

max 45mm

EZN
EZV
EZJ

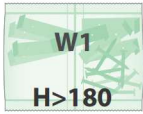
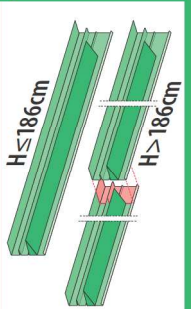
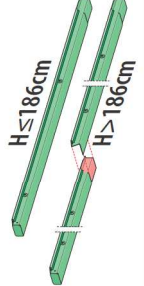
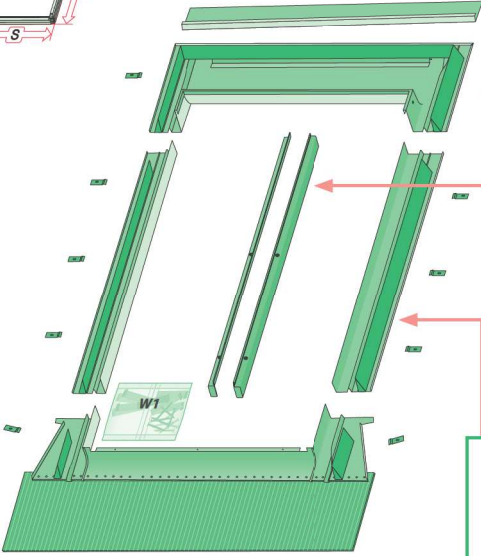
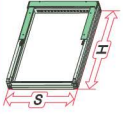

1a

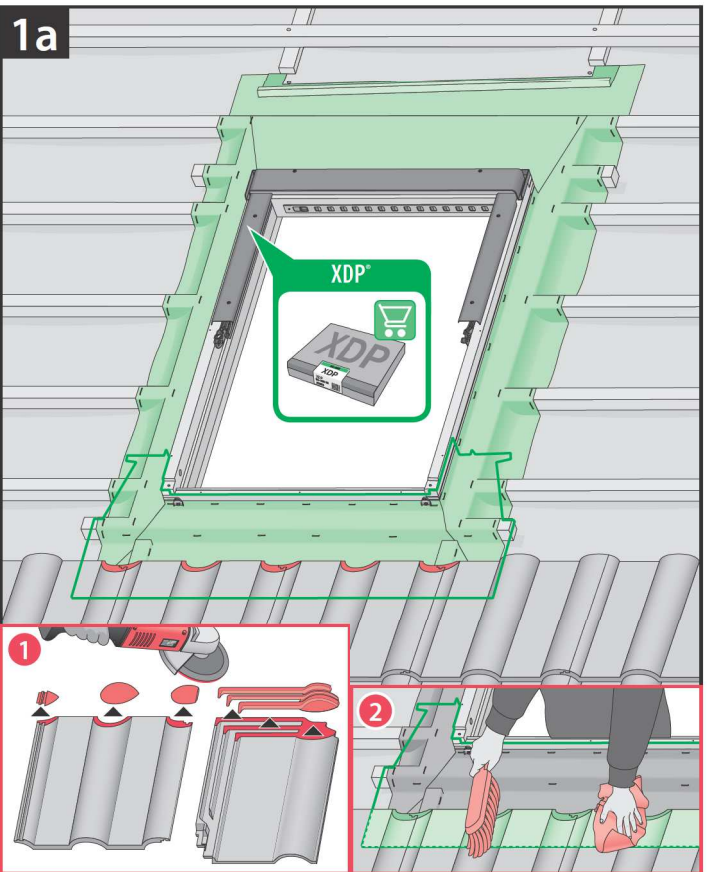

1b

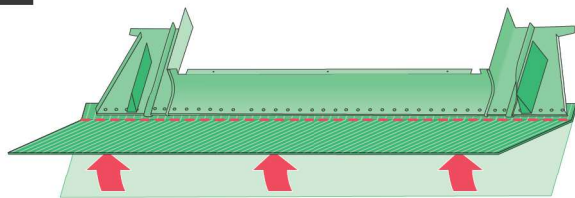

1



2

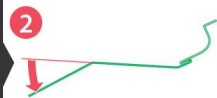

3

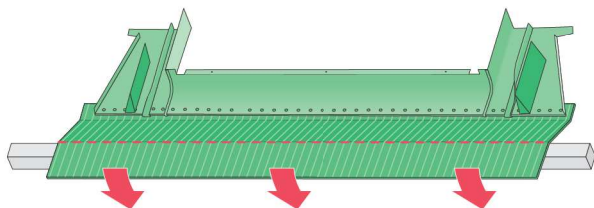
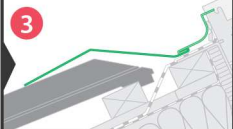

1c

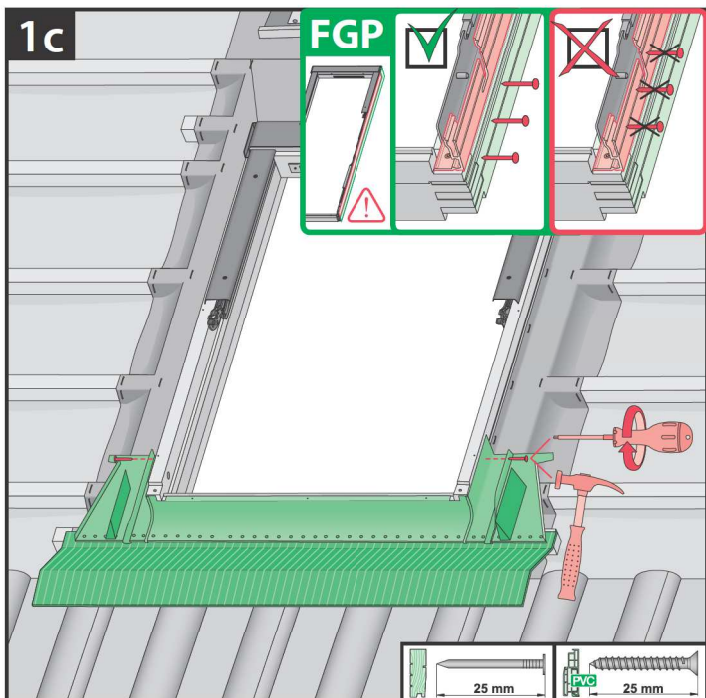
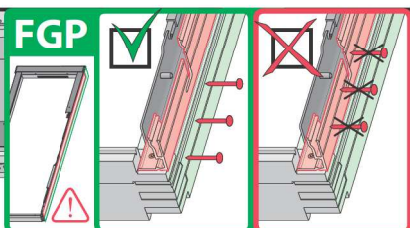

1c*

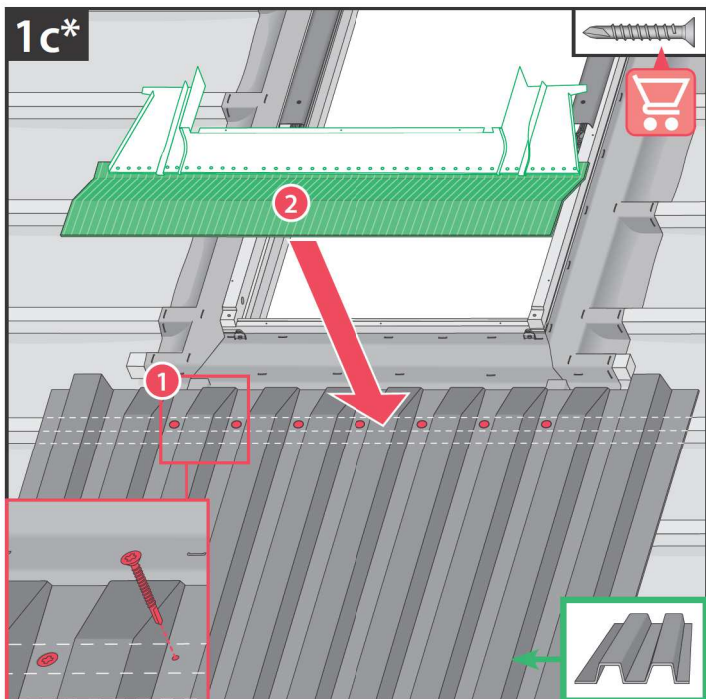

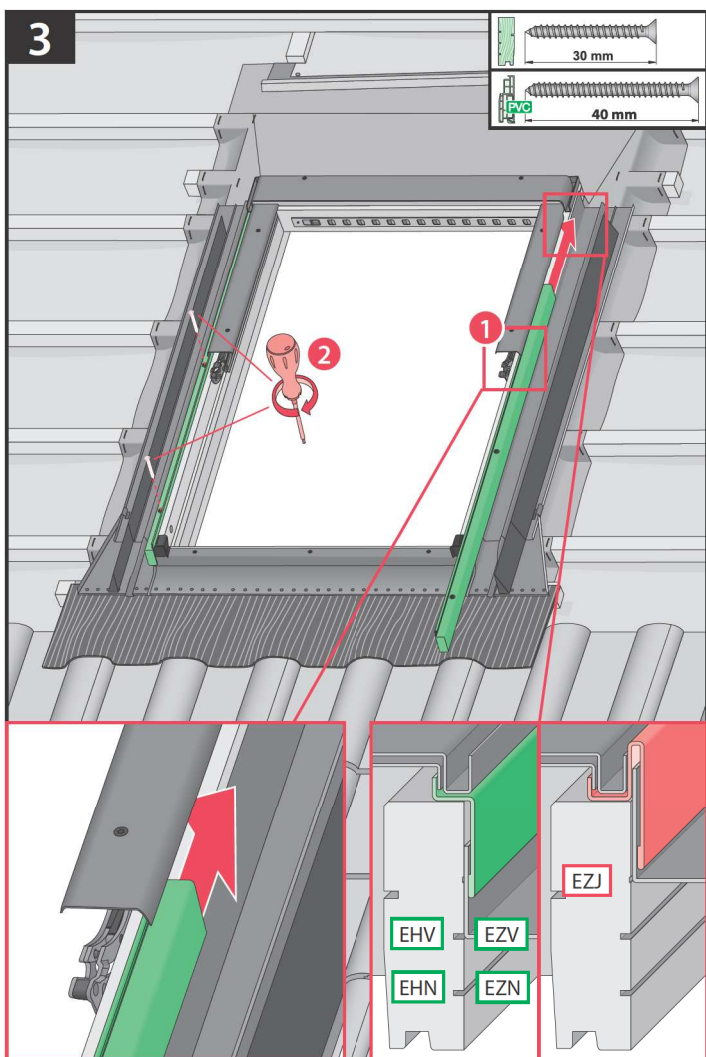
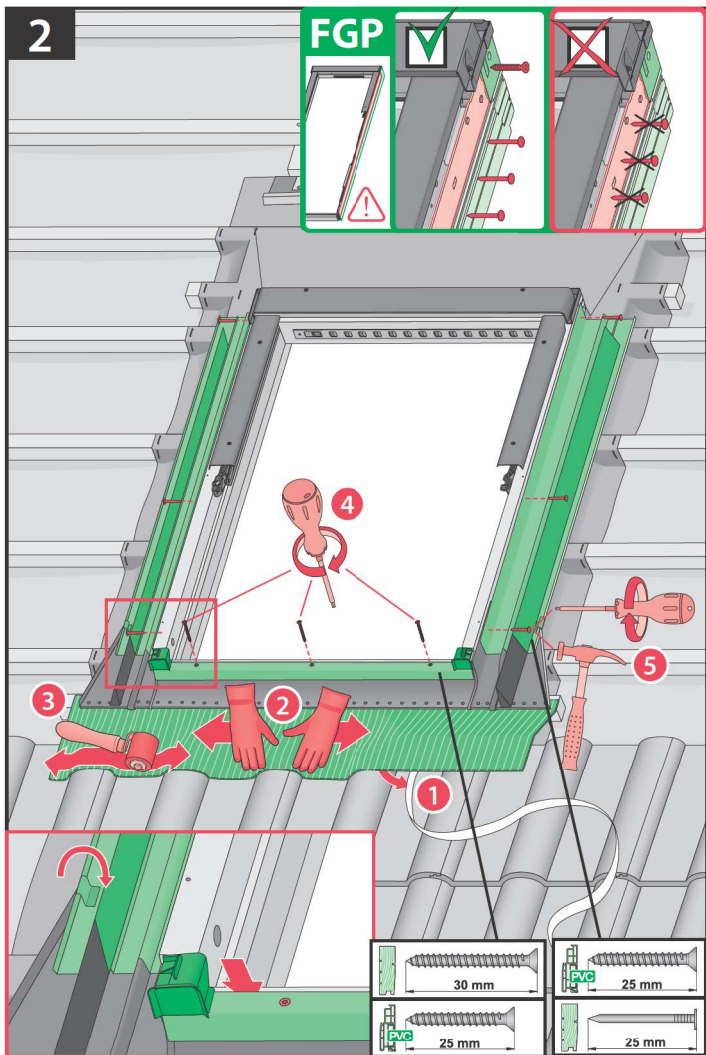

4

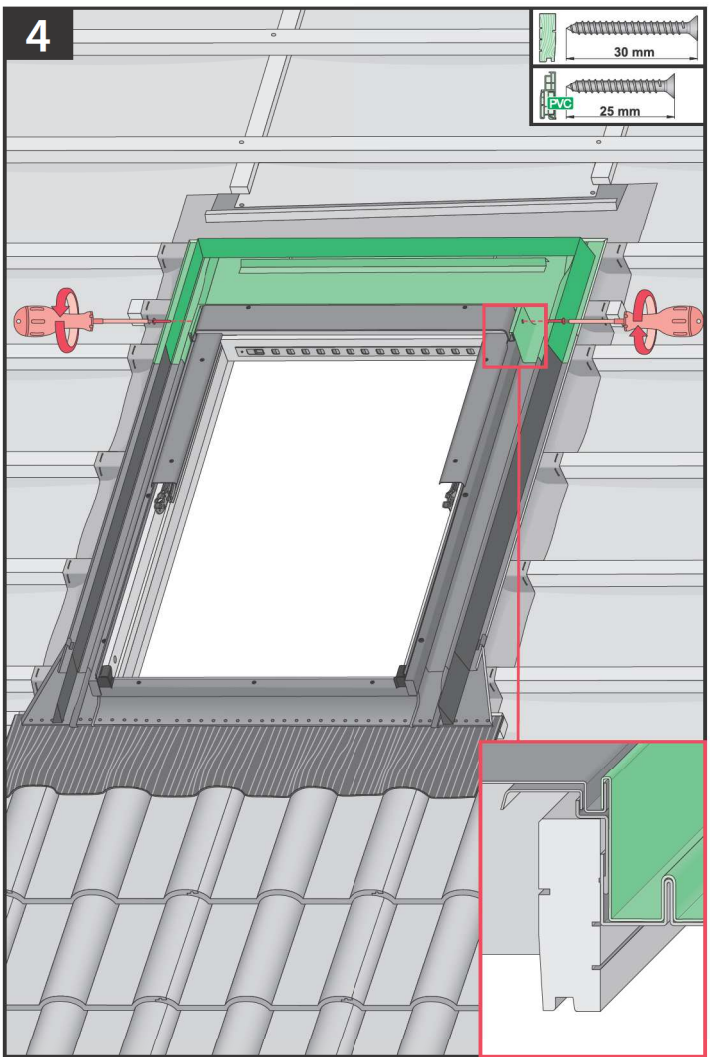

5

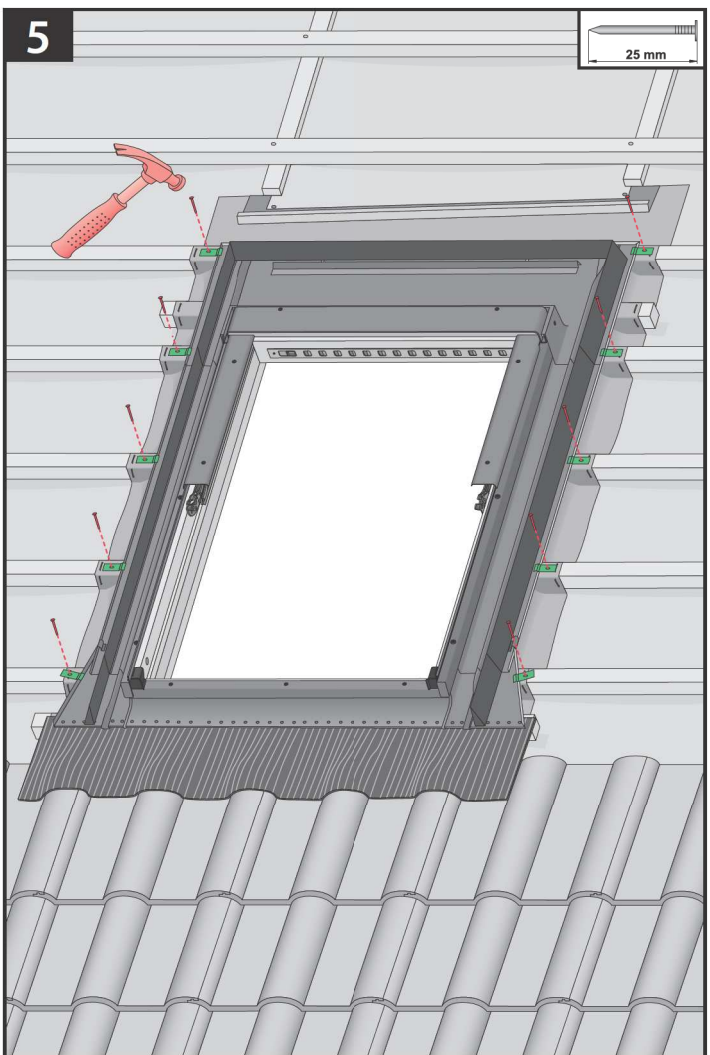

6

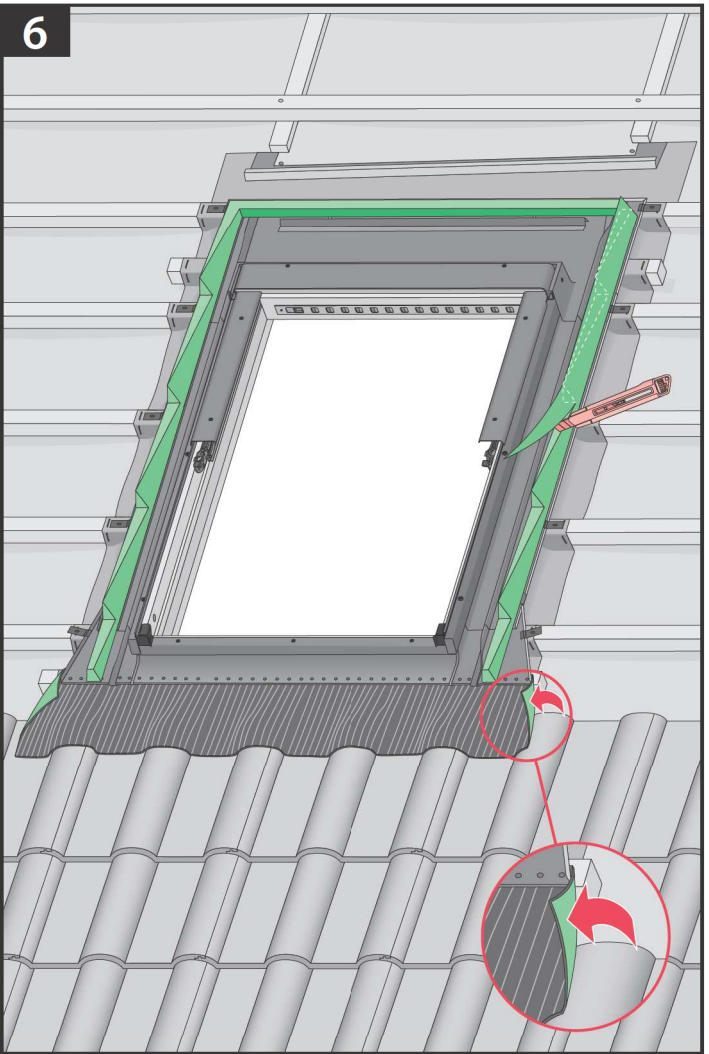

7

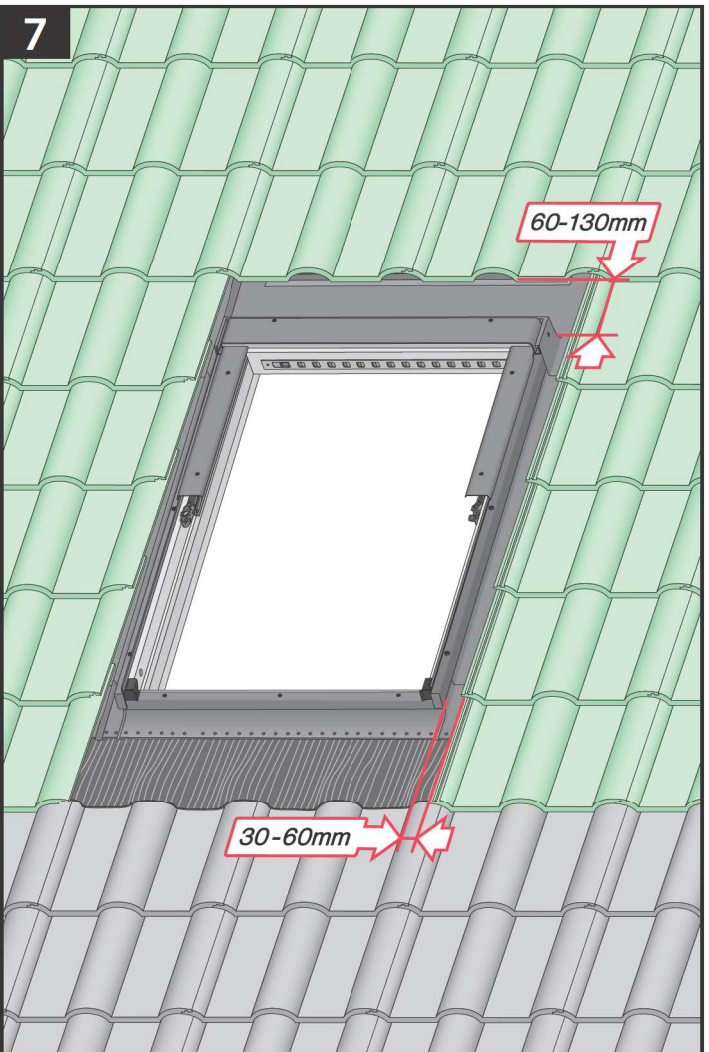

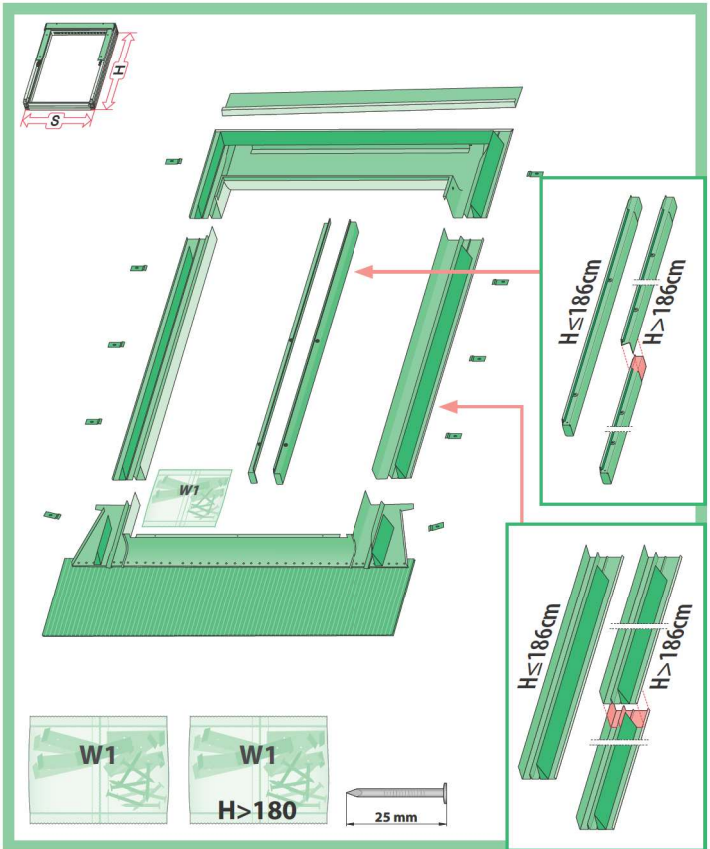
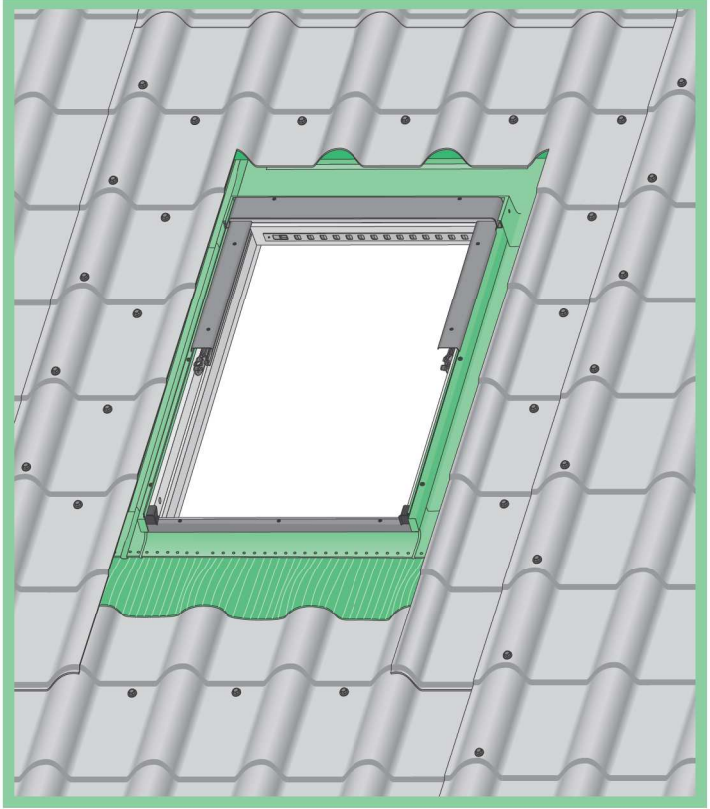
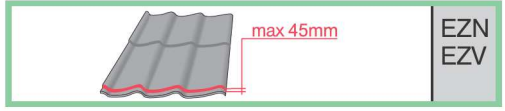

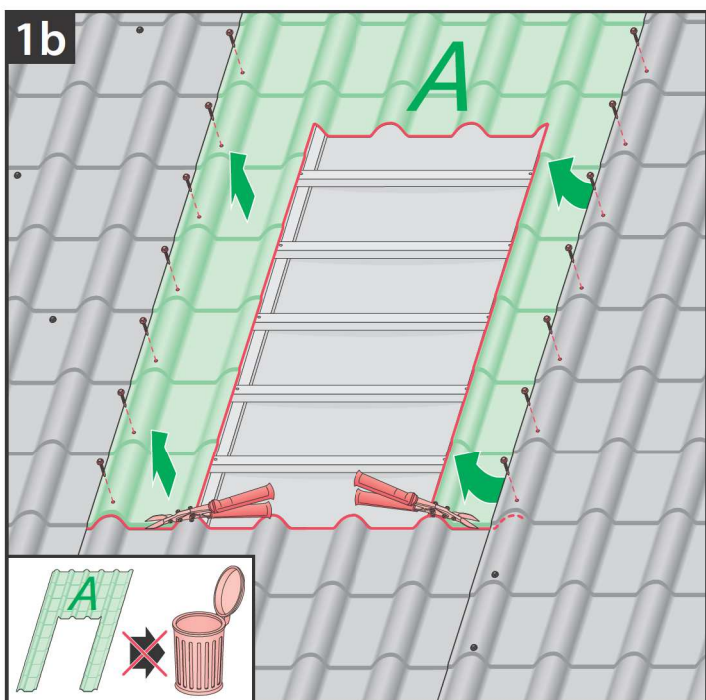
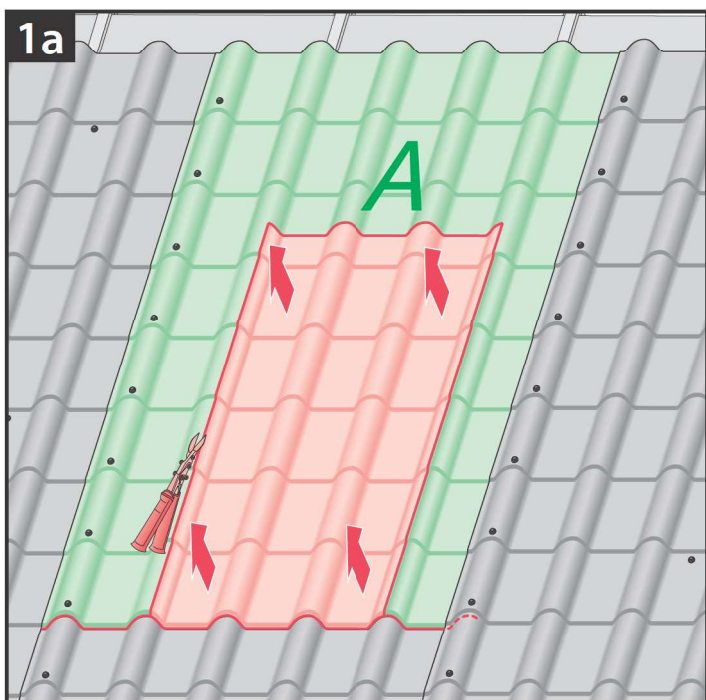
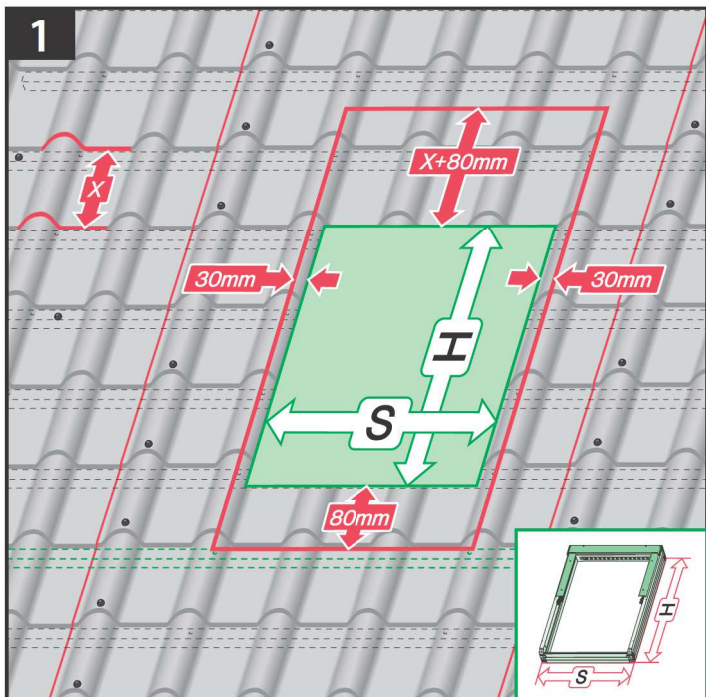

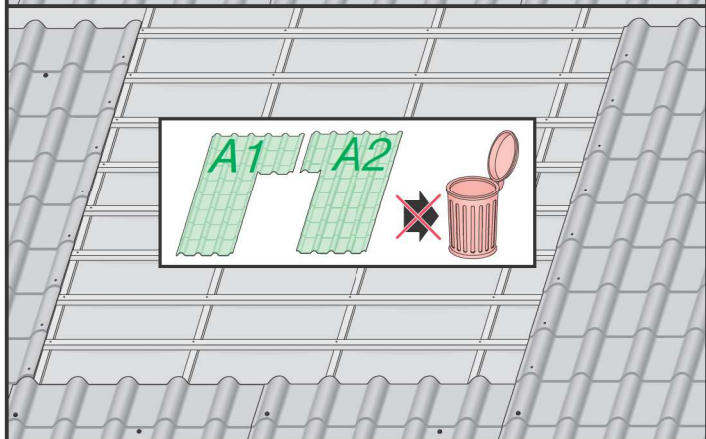
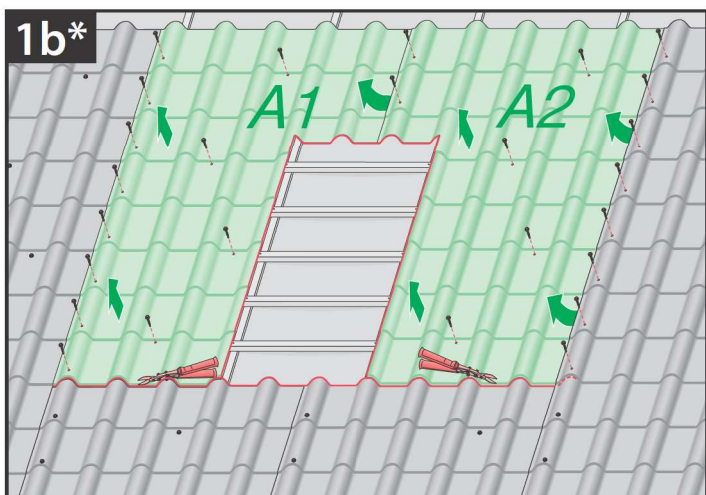
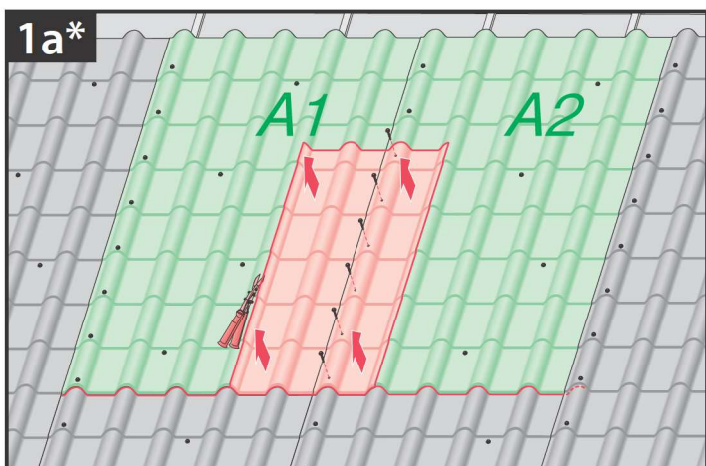
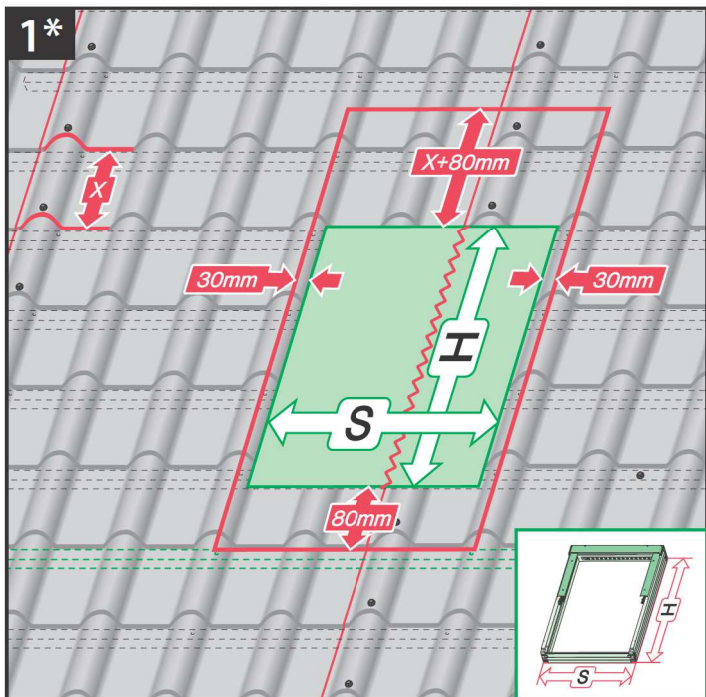

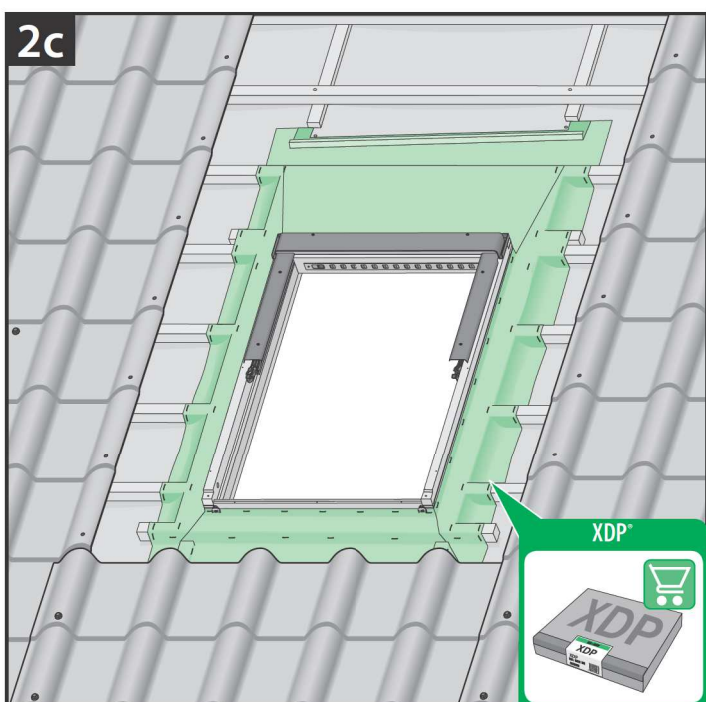
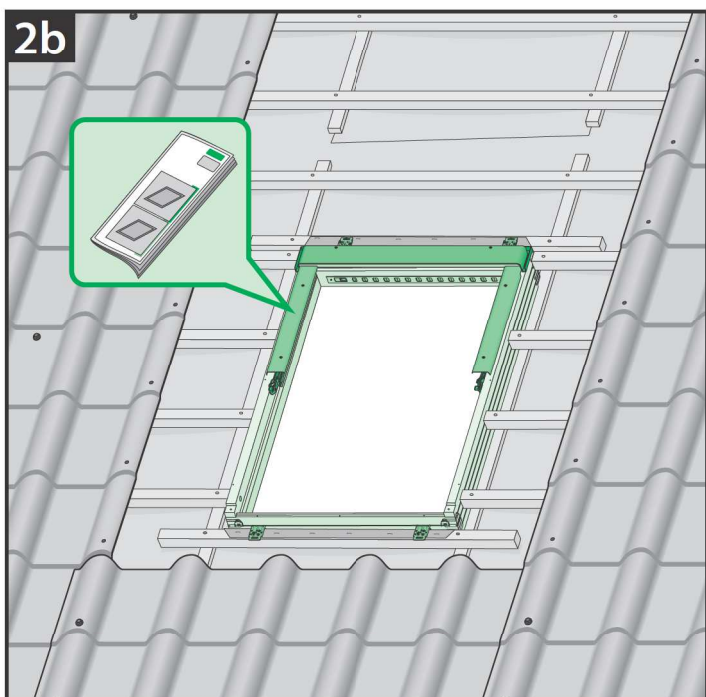
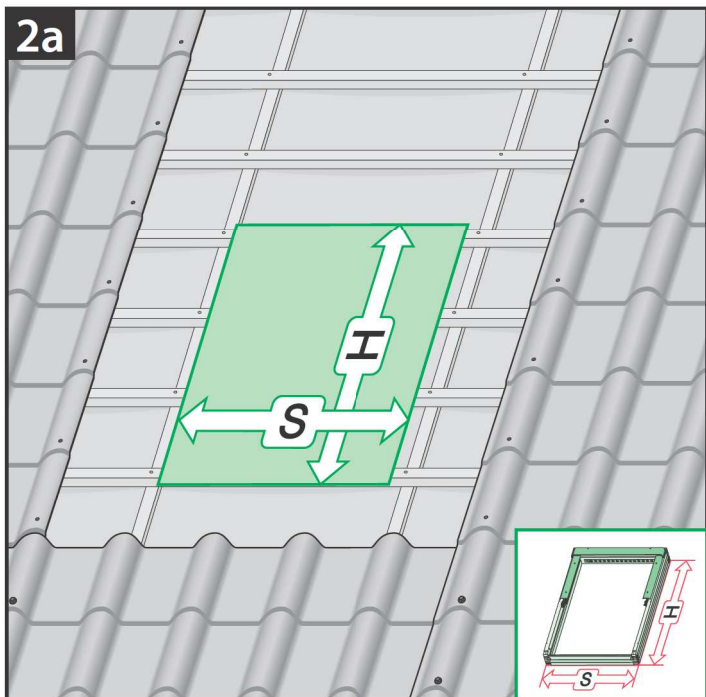

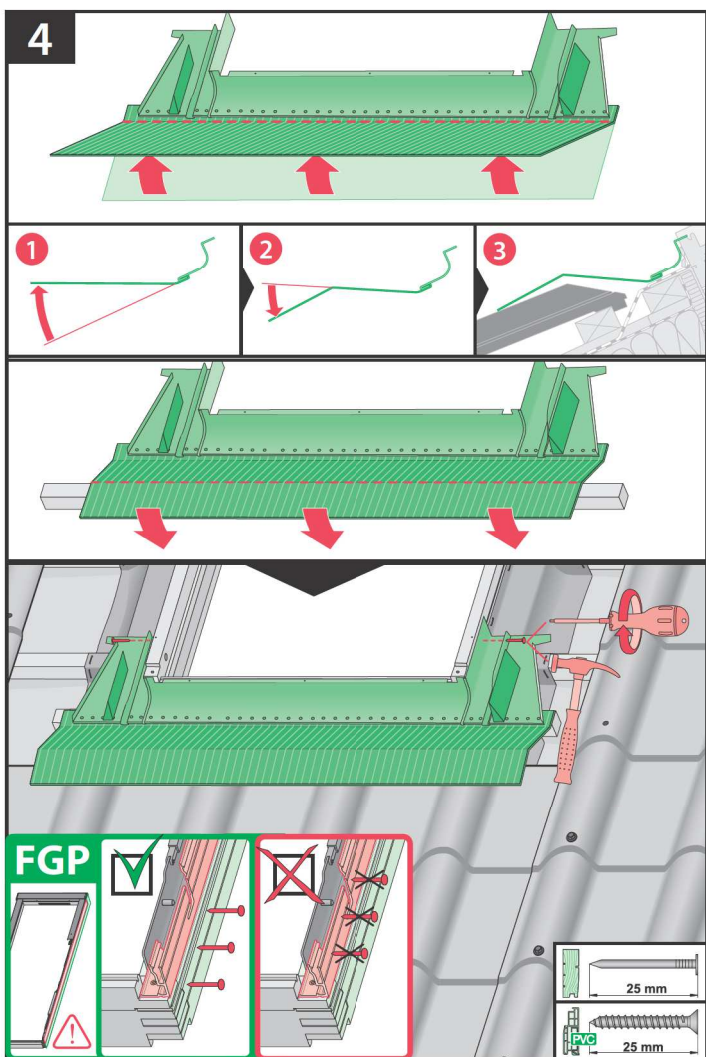
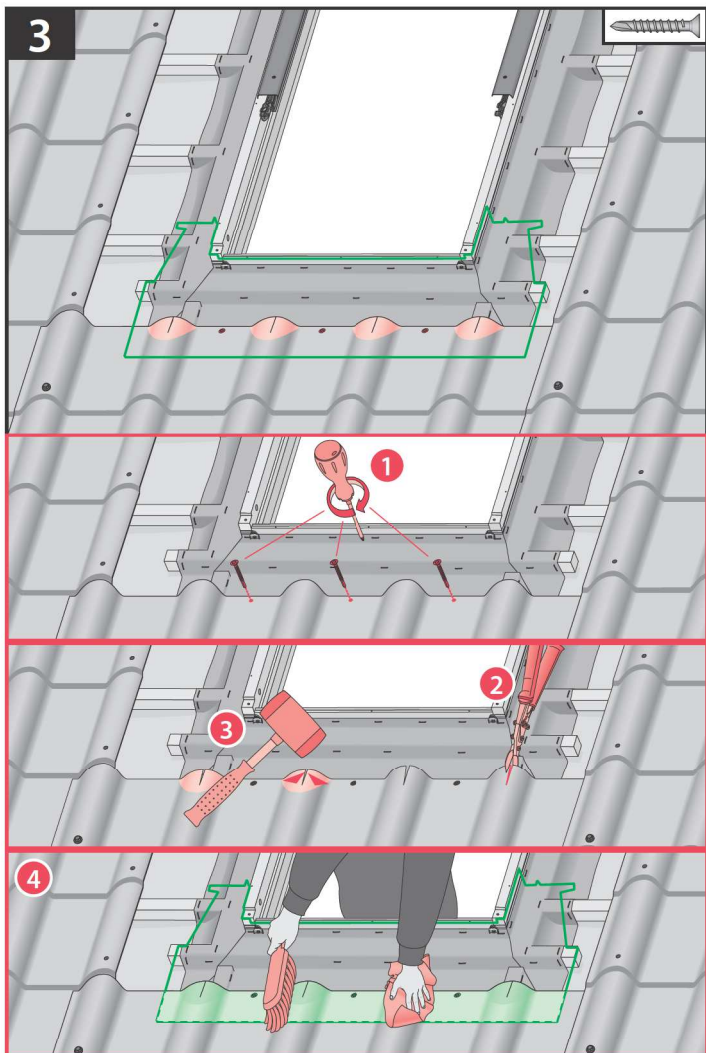

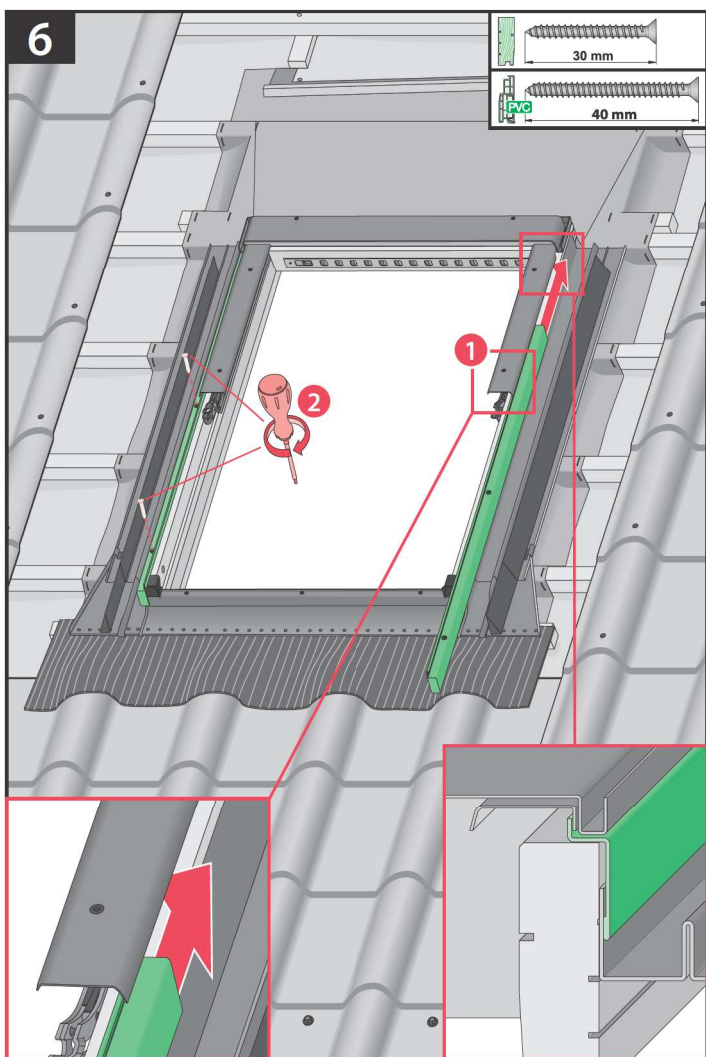
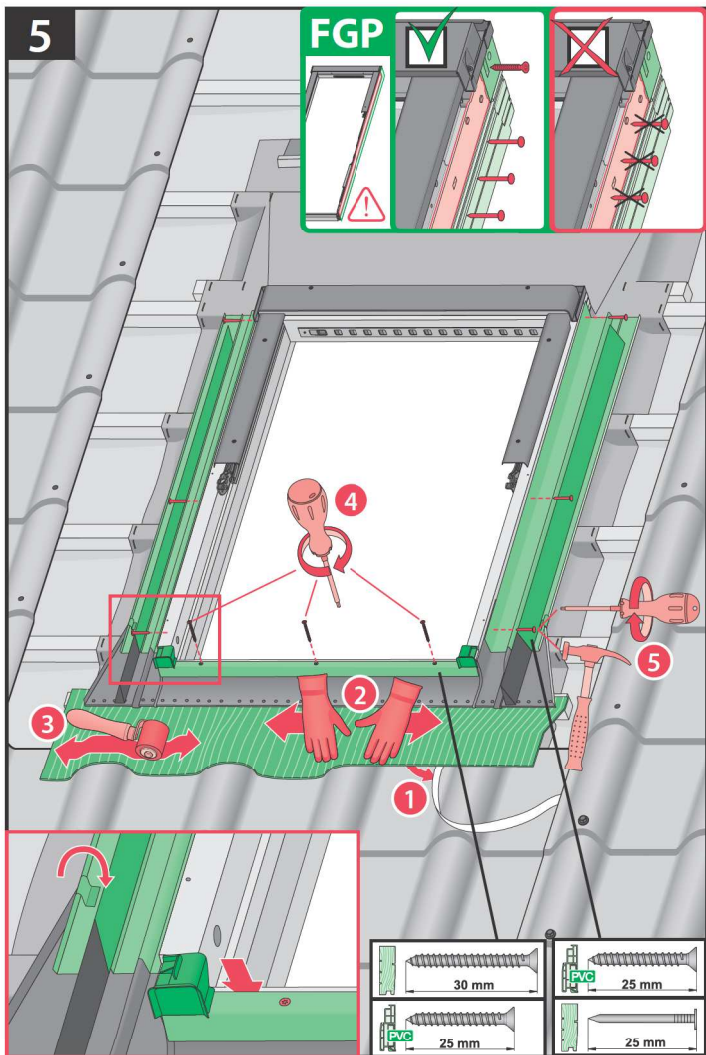

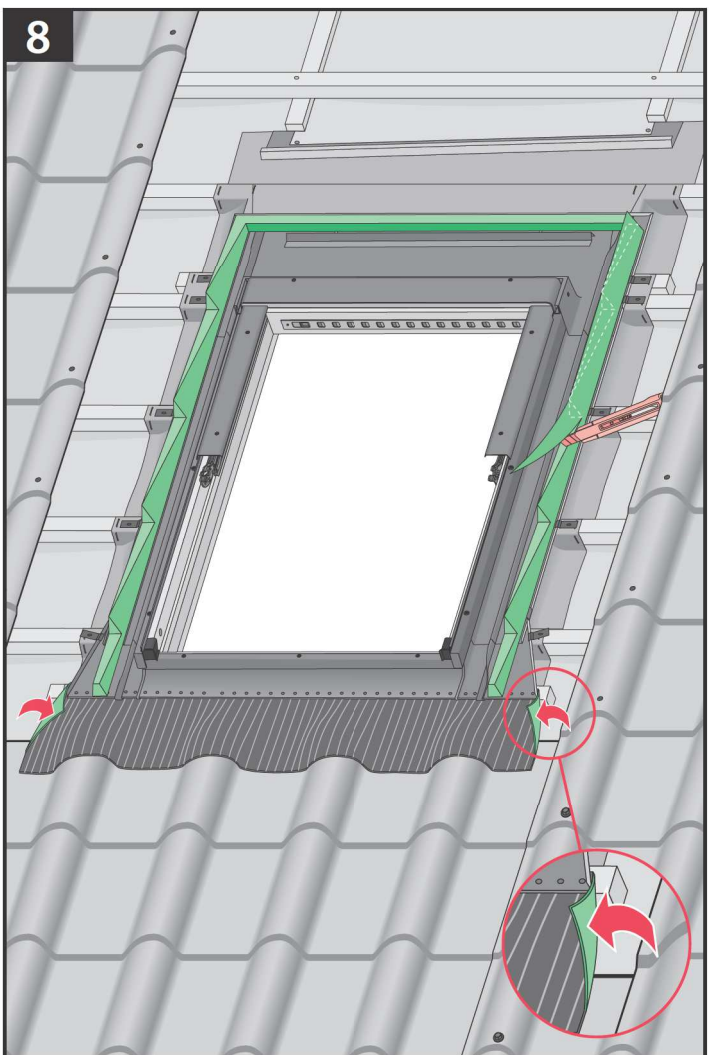
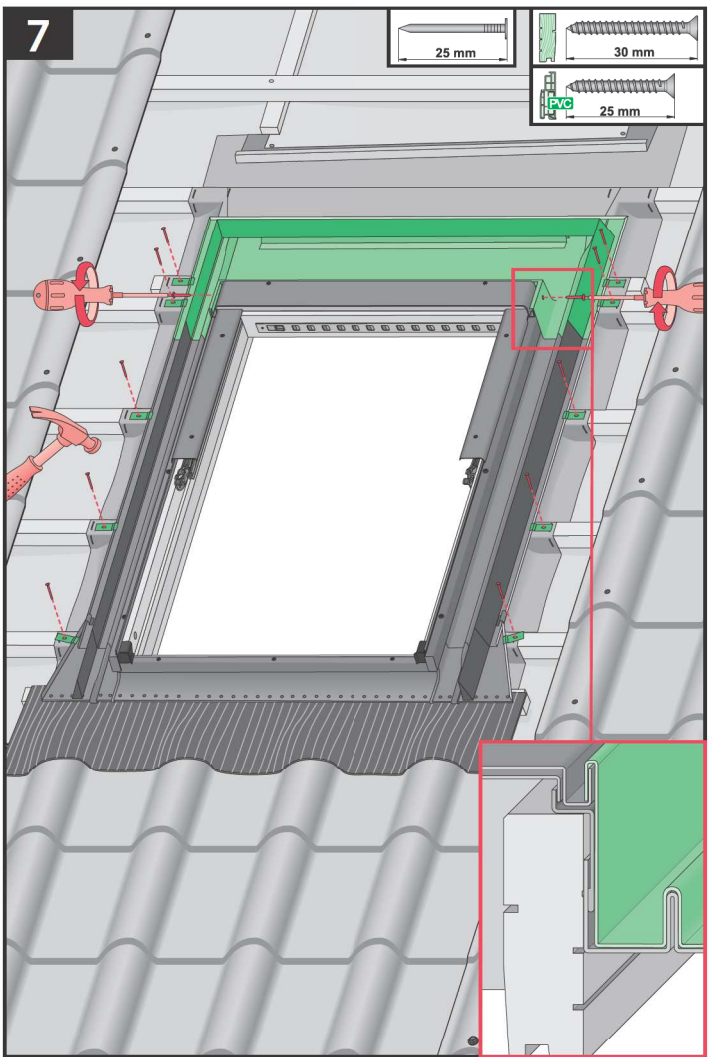

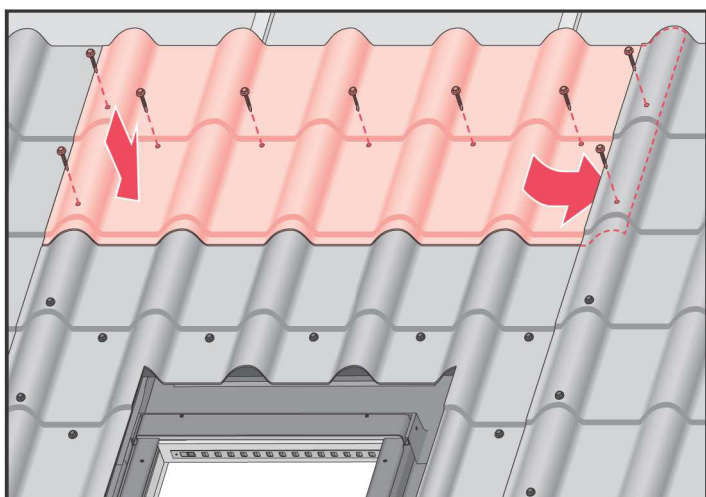
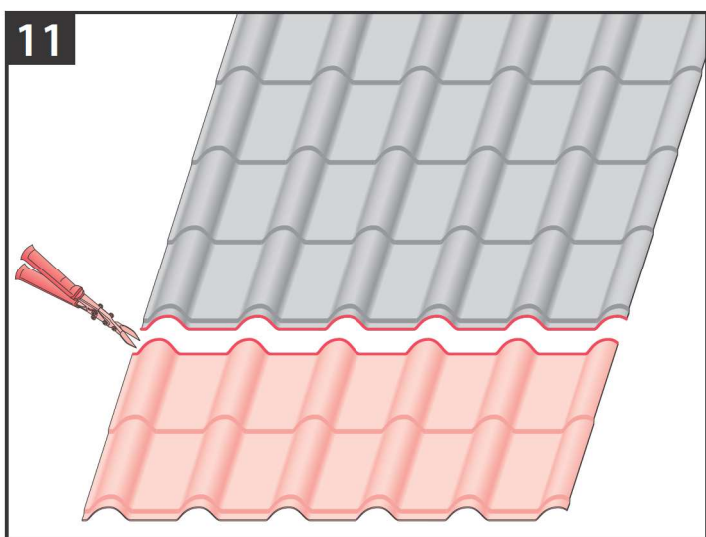
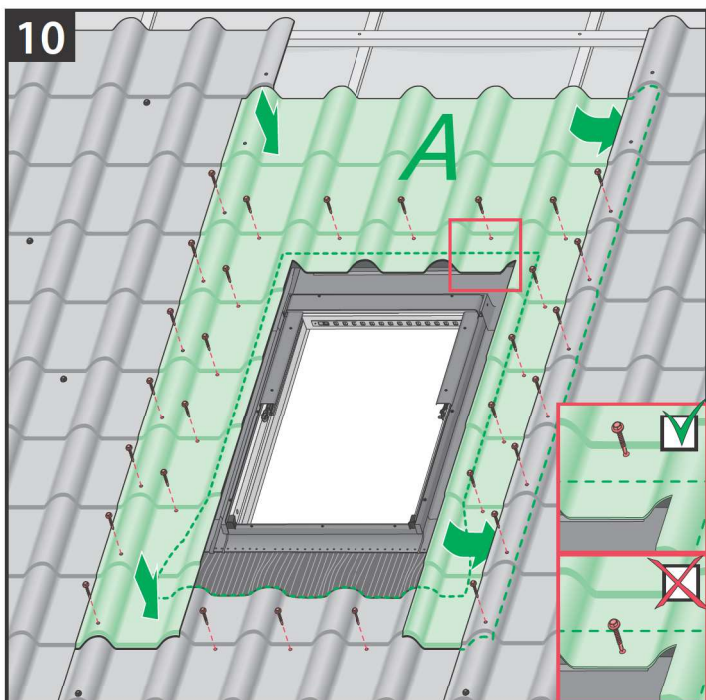
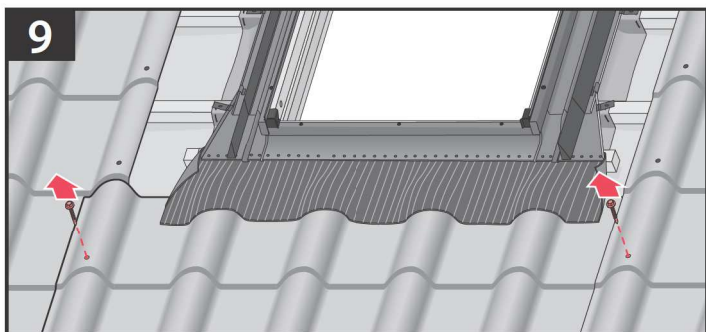

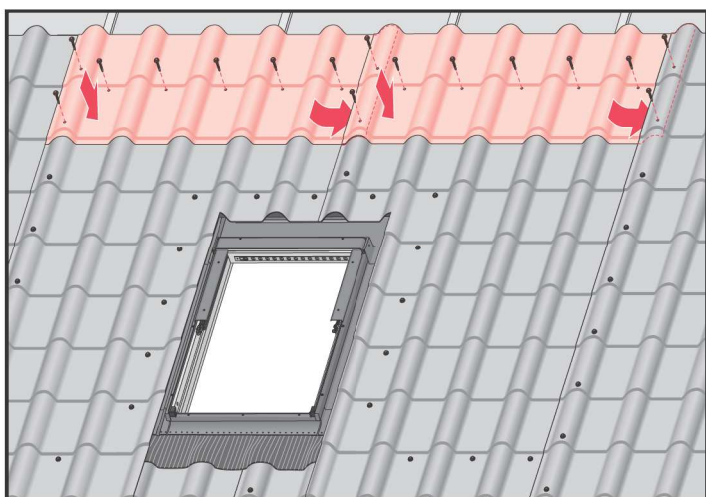
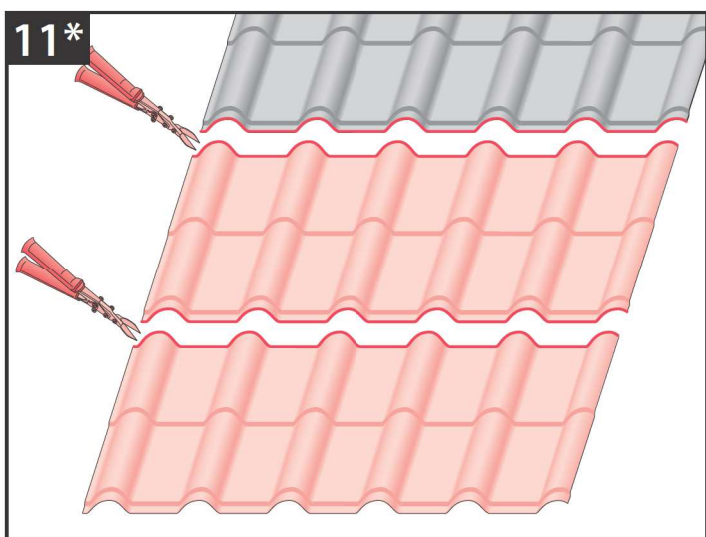
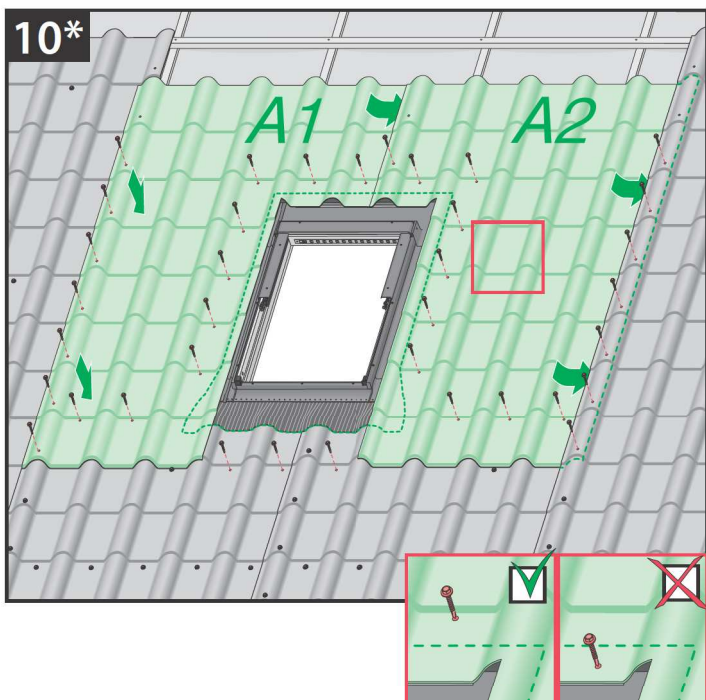
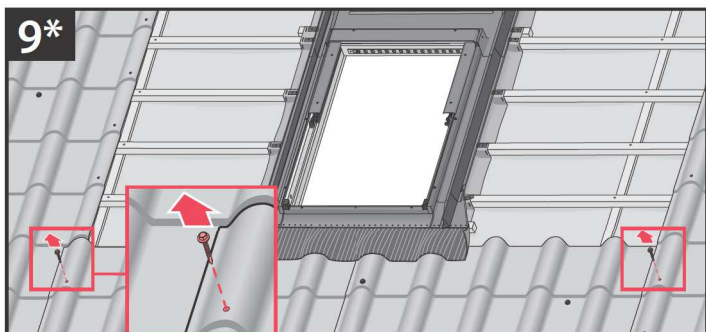

0 [cm] 1 2 3 4 5 6 7 8 9 10 11 12 13 14 15 16 17 18 19 20

BG	Производител и Продавач не носят отговорност за неспазване на съответните закони, строителни норми и изисквания за безопасност от потребителя на продукта, архитекта, монтажника или собственика на сградата.	LT	Ražotajs ir mazumtirgotājs neuzņemas atbildību par likumi, noteikumi un drošības prasību neievērošanu no produkta lietotāja, arhitekta, uzstādītāja vai ēkas īpašnieka puses.
CZ	Výrobce ani prodejce nenesou žádnou odpovědnost za nedodržení příslušných platných zákonů, stavebních předpisů a bezpečnostních požadavků uživatelem výrobku, architektem, montážníkem nebo vlastníkem budovy.	LV	Ģarantažs ir pārdevējs neņems nekādu atbildību uz tai, kad ģarantažs lietoģajs, arhitekģas, montāģotģajs ar pastato saviņņikas nesaiģiko ģalģojanģu iģatģymģ, tģisģyklģu ir sģuģos reģikalģivģmģ.
DE	Hersteller und Verkäufer übernehmen keine Haftung für Nichtbeachtung entsprechender Rechts- und Bauvorschriften sowie Sicherheitsanforderungen seitens Produktbenutzers, Architekten, Monteure oder Gebäudebesitzers.	NL	De fabrikant en verkoper zijn niet aansprakelijk voor gevolgen bij het niet opvolgen van toepasselijke wetten, bouwbesluiten en veiligheidsvoorschriften door de gebruiker van het product, de architect, de installateur of de eigenaar van het gebouw.
EE	Tootja ja jaeimģiģja ei vastuta toote kasutaja, arhitekti, paigaldaja vģi hoone omaniku poolt kehtivate seaduste, mģaruste ja ohutusnģuete mitteeģarģimise eest.	PL	Producent i Sprzedawca nie ponosi zadnej odpowiedzialnoģci za nieprzeģstzeģanie stosownych przepisģw prawa, przepisģw budowlanych i wymoģoģw bezpieczeģstwa przez uzytkownikģa produktu, architekta, montaģystę lub wlaģciociela budynku.
ES	El fabricante y el vendedor no tienen ninguna responsabilidad por el incumplimiento de la ley vigente, normas de construcciģn y exigencias de seguridad por parte del usuario del producto, arquitecto, instalador o el propietario del edificio.	PT	O fabricante e o vendedor nģo tem nenhuma responsabilidade pelo o nģo cumprimento da lei, cģdigos de construçģo e as exigencias de segurança por parte do usuģrio do produto, arquiteto, instalador ou proprietģrio do edifģcio.
FR	Le fabricant et le revendeur ne prend aucune responsabilitģ de ne pas respecter les lois applicables, les rģglementations sur les bģtiments et les exigences de sģcuritģ par l'utilisateuģ du produit, l'architecte, l'installateur ou le propriģtaire du bģtiment.	RO	Nici producģtorul, nici distribuģtorul nu ģģi vor asuma niciun fel de raspundere pentru nerespectarea legilor ģi vigoare, a legilor din domeniul construcģilor sau a mģsurilor de siguranģă ģmpuse utilizatorilor produsului, arhitecģilor, montaģorilor sau proprietarilor cģadģri.
GB	Manufacturer and Seller shall bear no liability for failure to comply with the applicable laws, building codes and safety requirements by the user of the product, architect, fitter or owner of the building.	RU	В случģe несоблģдения архитектором, монтажником или владельцем здания строительных правил и норм безопасности ответственность с производителя и продавца снимается.
HU	A gyģrģntģ es a forgalmazģ nem vállal semmifelģ felelģssģget a vonatkozģ törvģny, ępítģpari ęs biztonsģgi elģrģsok tģrmeķfelhasznģlģ, ępítģsz, beępítģmester vagy ępģlletuģajdonos áltģli be nem tartģsģert.	SK	Vyrobca a predajca nenesģ žģdnģ zodpovednosť za nedodržanie prģslušnych ustanovenģ zģkona, stavebnģch predpisģv a bezpečnostnych poģžadavķev uģivateľom vģrobku, architektom, montģerom alebo majiteľom objektu.
IT	Il Produttore e il Rivenditore non potranno essere ritenuti responsabili per il mancato rispetto, da parte dell'utente del prodotto, del progettista, dell'installatore o del proprietario dell'edificio, delle leggi vigenti, nonchģ dei regolamenti edilizi e di quelli relativi alla sicurezza.		